

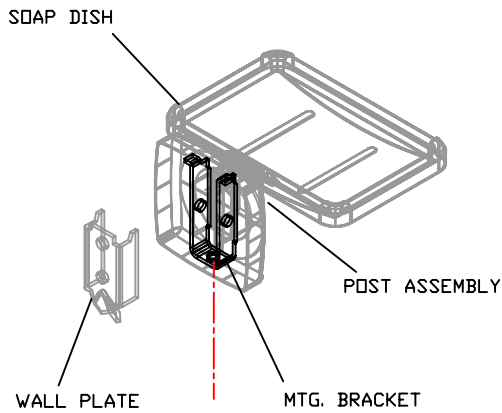

Technical Data

S-4911-XX

SOAP DISH WITH OUT DRAIN

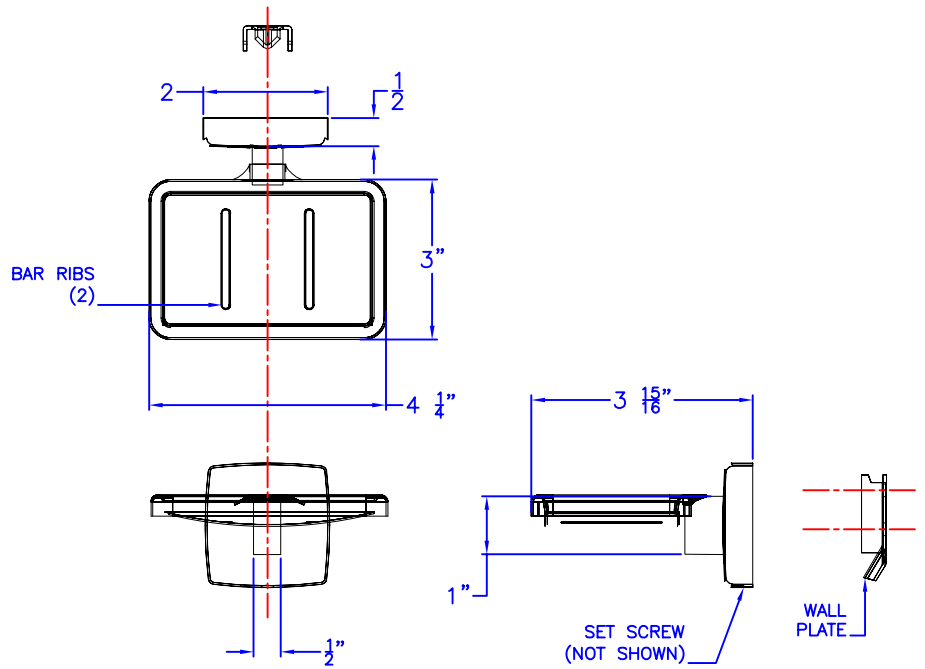

FINISHES:
 -SS SATIN STAINLESS
 -BS BRIGHT STAINLESS
 -PC POWDER COAT (SPECIFY COLOR)

Construction:

POST ASSEMBLY: 22 GAUGE TYPE 304 STAINLESS STEEL
 WALL PLATE: 16 GAUGE TYPE 304 STAINLESS STEEL WITH (2) .200Ø MTG. HOLES
 MOUNTING BRACKET: 16 GAUGE TYPE 304 STAINLESS STEEL
 SOAP DISH: 22 GAUGE TYPE 304 STAINLESS STEEL STAMPED FORMED
 SET SCREW: 8-32 X $\frac{5}{16}$ "
 MOUNTING SCREWS: #8 X 1 $\frac{1}{4}$ " PHIL. PAN HD. ZINC PLATE
 FINISHES AS NOTED.

Installation:

FASTEN WALL PLATE.
 TILT POST ASSEMBLY UP SLIGHTLY AND ENGAGE OVER WALL PLATE AND PUSH DOWN TO LEVEL.
 (SET SCREW HOLE AND POST SEAM ARE TOWARDS FLOOR OR DOWN)
 THREAD SET SCREW THROUGH POST FLANGE AND MOUNTING BRACKET UNTIL TIGHT.

CAUTION: UNIT IS ONLY AS STRONG AS THE ANCHORING DEVICES AND THE WALL ON WHICH IT IS MOUNTED TO.

Guide Specification:

SINGLE BAR SOAP HOLDER.
 CONCEALED MOUNTING SYSTEM.
 FABRICATED FROM TYPE 304 STAINLESS STEEL.

The manufacturer reserves the right to make changes in design and material without formal notice and without incurring obligation

© Copyright 2005
 Brey-Krause Manufacturing

Brey-Krause Manufacturing
 1209 West Lehigh Street, Bethlehem, PA 18018
 Phone: 610.867.1401 Fax: 610.866.1433
 www.breykrause.com